

Thermomix® UFH control pack

t: 01923 249026 m: 07941 169635 w: www.gs-ufh.co.uk e: gs@warmfloors.co.uk

UFHC970302 Thermomix® UFH Control Pack with 'A' rated pump BVAL900001
3/4" Isolating Ball Valve



Overview

A unique, patented, modular control pack for underfloor heating systems. Designed to be lightweight and compact in order to connect directly onto a standard UFH manifold without the need for extra brackets or support. The control pack consists of a mixing valve, circulating pump, connection elbow, manifold adaptors and all necessary seals. The control pack elbow includes a 1/2" tapping for the connection of an overheat thermostat or pressure and/or temperature gauges.

Thermomix® UFH control pack

t: 01923 249026 m: 07941 169635 w: www.gs-ufh.co.uk e: gs@warmfloors.co.uk

Features and Benefits

- Compact bolt on unit providing quick and simple installation
- Provides controlled mixed temperature water to underfloor heating systems
- Easy set up within the adjustable range of 25°C to 60°C
- Controls flow temperature to +/- 2°C even with changing boiler flow and return temperatures
- Nickel plated control pack to match stainless steel UFH manifold
- Blanking cap and pump union can be interchanged, so the pack can be reversed
- Connection point for overheat thermostat or gauges included

Materials

Valve body	Gunmetal
Seals	Tensit
O-Rings	Viton
Spring	Stainless steel

Specifications

Maximum static pressure	10 bar
Maximum temperature	90°C
Adjustable control range	25°C - 60°C
Factory pre-set Connection sizes	25°C (minimum) ¾" FBSP (mixer) 1" MBSP (manifold)

Typical Installation

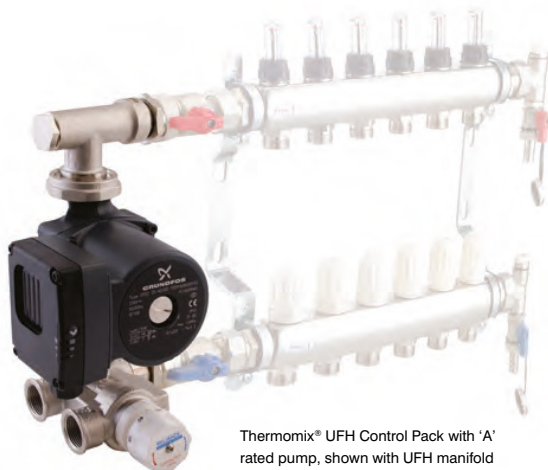

Thermomix® UFH Control Pack with 'A' rated pump, shown with UFH manifold (available separately)

Flow Rates

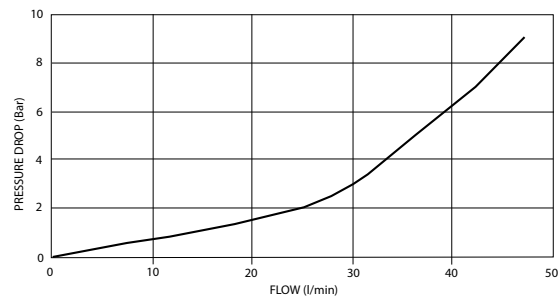

Dimensions

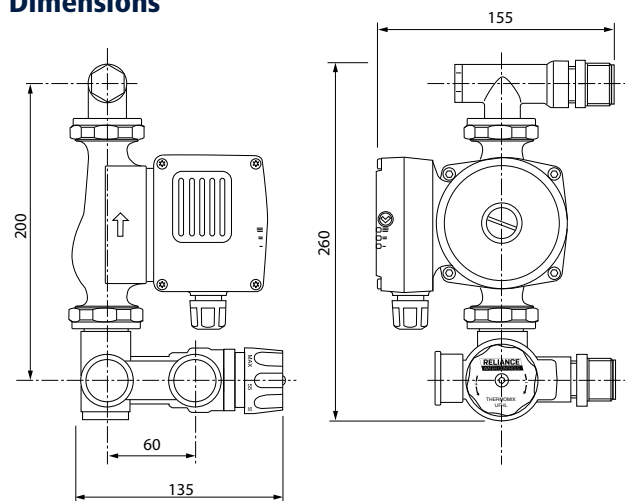

All dimensions shown in mm unless otherwise stated